



A RANDOM FOREST REGRESSION BASED SPACE VECTOR PWM INVERTER CONTROLLER FOR THE INDUCTION MOTOR DRIVE

M Laxmana Rao, CH PRASANNA, D. PRASAD RAO, S. ADINARAYANA REDDY
5. R. SRINIVAS

Assistant Professor,
Department of EEE, Elenki College of Engineering,
Hyderabad

Abstract:

This paper presents a random forest (RF) regression based implementation of space vector pulse width modulation (SVPWM) for a two-level inverter to improve the performance of the three-phase induction motor (TIM) drive. The RF scheme offers the advantage of rapid implementation and improved prediction for the SVPWM algorithm to improve the performance of a conventional space vector modulation scheme. In order to show the superiority of the proposed RF technique to other techniques, an adaptive neuro fuzzy inference system (ANFIS) and artificial neural network (ANN) based SVPWM schemes are also used and compared. The proposed speed controller uses a backtracking search algorithm to search for the best values for the proportional-integral controller parameters. The robustness of the RF-based SVPWM is found superior to the ANFIS and ANN controllers in all tested cases in terms of damping capability, settling time, steady-state error, and transient response under different operating conditions. The prototype of the optimal RF-based SVPWM inverter controller of induction motor drive is fabricated and tested. Several experimental results show that there is a good agreement of the speed response and stator current with the simulation results which are verified and validated the performance of the proposed RF based SVPWM inverter controller. schemes the SVPWM technique

is the best method for VSI because of lower switching losses and its ability to minimize the harmonic output signals produced by the inverter. In Piao and Hung reported a unified SVPWM technique for a multilevel inverter that requires complex nonlinear calculation involving modulation implicit functions of SVPWM. In

INTRODUCTION

Over the last several decades voltage source inverter (VSI) based variable frequency drive has been widely utilized in various industrial applications, such as power supplies, active filter, and induction motor (IM) drives. The performance of VSI depends on the switching control scheme of the insulated-gate bipolar transistors (IGBTs) in the inverter for generating less harmonic waveforms. There are many switching control techniques, such as sinusoidal pulse width modulation (SPWM), space vector pulse width modulation (SVPWM), carrier-based PWM, selective harmonic elimination PWM, and harmonic band PWM, respectively. Among previous control

general, most of the SVPWM requires complex online computation which leads to difficulty in realtime implementation. That is why only simulation results are presented.

Over the years, proportional-integral-derivative (PID) controllers have been widely used for a three-phase induction motor (TIM) in industrial applications due to its easy implementation, simple design, and structure.

However, it requires a mathematical model and a trial and error procedure to find the best PID control parameters. This paper uses backtracking search algorithm (BSA) to overcome these problems through a search for the best values of the PI speed controller

parameters. In this paper, a prototype of the RF-based SVPWM inverter controller is implemented to justify the simulation results by the experimental results and to validate the performance of the proposed controller.

Many contemporary research work used new machine learning techniques to overcome the problems of artificial intelligence. One of the most important of these methods is the random forests (RF) regression technique, which has been used to develop the actual image spectra, and to improve rainfall rate assignment during day, night, and twilight. In used RF regression to vote for the optimal positions, leading to robust and accurate results. RF regression is also used to choose groups of the metabolites and transcripts which show association with potato tuber flesh color and enzymatic discoloration.

In, RF techniques are used to improve image segmentation and to predict churn in the banking industry, respectively. Therefore, this paper proposes the RF regression based SVPWM technique to minimize the complex online computation required for real-time implementation. This is a cost-effective approach that does not limit the choices of switching frequencies for linear and nonlinear functions and, thus, it leads to fast and accurate results. RF gives the results through predictors in each tree depending on the probability and the statistical operations. It produces better results than those of both ANFIS and ANN techniques. LITERATURE SURVEY

Discontinuous SVPWM Techniques of Three-Leg VSI-Fed Balanced Two-phase Loads for Reduced Switching Losses and Current Ripple

In this paper, various types of discontinuous space vector pulse-width modulation techniques for a three-leg voltage source inverter supplying balanced two-phase loads are proposed. The main objectives of the paper are to analyze switching loss

characteristics associated with semiconductor devices and to reduce output current ripple by dealing with various types of zero space vector time in each switching sequence. Capabilities of reductions in switching losses and current ripple for both balanced and unbalanced output phase voltages at high modulation index and load power factor angle of 30° lagging are focused. The validity of the proposed techniques is verified by simulation and experimental results in terms of voltage spectrum, current waveforms, reductions in switching losses, and output current ripple at high modulation index when compared to a continuous space vector pulse-width modulation technique.

Sensor less SVPWM-FADTC of a New Flux-Modulated Permanent-Magnet Wheel Motor Based on a Wide-Speed Sliding Mode Observer This paper presents a sensor less flux adaption-direct torque control (FADTC) for a new flux-modulated permanent-magnet (FMPM) wheel motor, in which space vector pulse width modulation (SVPWM) and a wide-speed sliding mode observer (SMO) are adopted. SVPWM-FADTC has several advantages over conventional hysteresis direct torque control, such as low torque/flux ripples in motor drive and reduced direct axis current when the motor is operated at a light or a sudden increased load. To achieve the sensor less control of SVPWM-FADTC system, a wide-speed SMO is proposed. Compared with conventional SMO, system chattering is improved, the low-pass filter and the phase compensation are eliminated, and the estimation accuracy of the rotor position at low speed is enhanced. Numerical simulations and experiments with a 2-kW FMPM wheel motor are carried out. The results verify the feasibility and effectiveness of the proposed sensor less SVPWM-FADTC method adopted by the FMPM wheel motor.

Methodology

The RF method, which was first proposed by Breiman in 2001, is a set of predictors that depend on trees in the forests through the random input values of each tree. The RF regression consists of many trees and selects random subsets of the number of different predictors tested at each node. To build or

grow the trees, a deterministic algorithm is developed to select each tree from a random set of variables and

the training data are taken as random sample . The node is used to divide the nodes for minimizing from the total number through description available for analysis. The sampled random vector and standard RF are mixed as predictors for each tree with the same distribution for all trees in the forest.

RANDOM FOREST ALGORITHM

Random forest algorithm is a supervised classification algorithm. As the name suggest, this algorithm creates the forest with a number of trees. In general, the more trees in the forest the more robust the forest looks like. In the same way in the random forest classifier, the higher the number of trees in the forest gives the high accuracy results. If you know the decision tree algorithm.

ANN-Based SVPWM:

ANN is used as a solution to problems, such as power system stability estimation, IM control, and power electronic systems due to its rapid implementation the ANN-based SVPWM (ANN-SVM) for a two level inverter based IM drive. The estimated error and accuracy is evaluated for the RF regression through the minimization of the mean square error (MSE). Finding the optimum trees in the forest depends on the MSE. Testing data passed through each split node, by sending it either to the right or to the left child until ending up at a le

show the superiority of the proposed technique. Several experimental results are analyzed and compared with simulation results to justify the optimal performance of the RF-SVM based inverter controller. Statistical analysis for one cycle of duty ratio (Ta) is also analyzed between the techniques. Details of simulation and experimental results are explained under different case studies as follows.

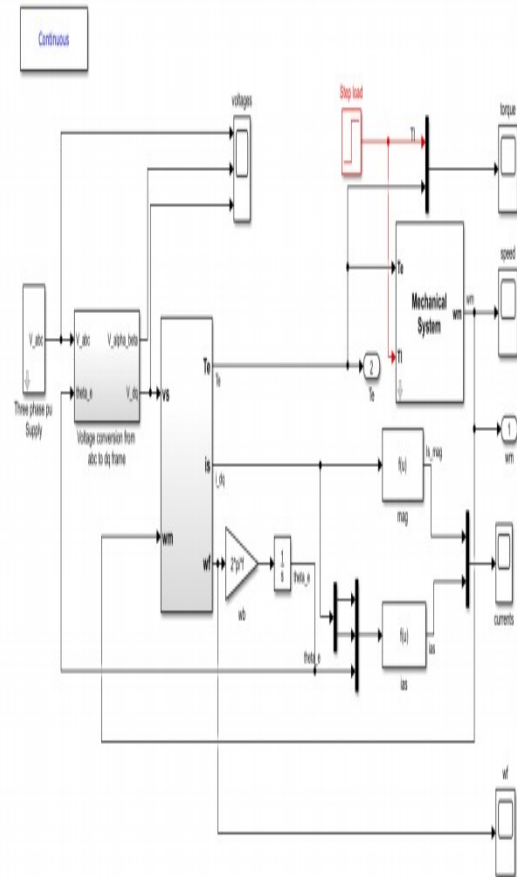

Fig.: the plot between Torque (PU) Vs Speed (PU)

Conclusion

This paper proposed a novel RF regression based SVPWM inverter controller for TIM drive to maximize damping capability and minimize ST, steady-state error, and transient response under different operating speed and load conditions. The idea of the proposed controller was to tune PI parameter by the BSA algorithm to find the best controller. An optimized speed controller then generates peak voltage by V/f control to SVPWM to generate the best switching pulse for the inverter. The objective function of the BSA algorithm was the

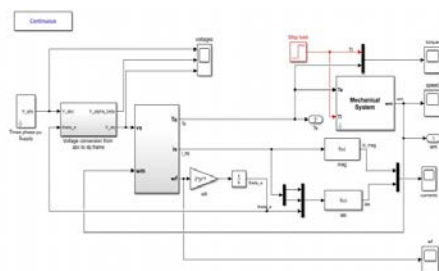

Fig.1: Simulink Model of the Proposed RF Regression forAn SVPWM Inverter.

RESULTS AND DISCUSSION

The performance of the RF regression based SVPWM (RFSVM) is investigated in simulation using MATLAB/Simulink and compared with the conventional SVM (C-SVM), ANFIS, and ANN- based SVM to

MAE of the speed that was designed to minimize the steady-state error, OS/undershoot, and ST. The performance of the simulation model of the proposed RF-SVM technique is compared with the ANN- and ANFIS-based SVM techniques under different speed and load conditions. It was found that in each case, the performance of the RF-based SVPWM technique is superior to both ANN-SVM and ANFIS-SVM techniques in terms of damping capability, ST, steady-state error, and transient response under different operating speed and load conditions. This is due to the advantages of RF regression which does not need large training data and requires less training time. Thus, the computation burden of the intelligent systems such as ANN- and ANFIS-based SVPWM techniques is removed.

References

[1] E. Levi, I. N. W. Satiawan, N. Bodo, and M. Jones, "A space-vector modulation scheme for multilevel open-end winding five-phase drives," *IEEE Trans. Energy Convers.*, vol. 27, no. 1, pp. 1–10, Mar. 2012.

[2] D. G. Durgasukumar and M. K. Pathak, "Comparison of adaptive neurofuzzy-based spacevector modulation for two-level inverter," *Int. J. Elect. Power Energy Syst.*, vol. 38, no. 1, pp. 9–19, Jun. 2012.

[3] C. Charumit and V. Kinnares, "Discontinuous SVPWM techniques of three-leg VSI-fed balanced two-phase loads for reduced switching losses and current ripple," *IEEE Trans. Power Electron.*, vol. 30, no. 4, pp. 2191–2204, Apr. 2015.

[4] P. Zheng, P. Wang, Y. Sui, C. Tong, F. Wu, and

T. Li, "Near-five-vector SVPWM Algorithm for five-phase six-leg inverters under unbalanced load conditions," *J. Power Electron.*, vol. 14, no. 1, pp. 61–73, 2014.

[5] Y. Fan, L. Zhang, M. Cheng, and K. Chau, "Sensorless SVPWM-FADTC of a new fluxmodulated permanent-magnet wheel motor based on a widespeed sliding mode observer," *IEEE Trans. Ind. Electron.*, vol. 62, no. 5, pp. 3143–3151, May 2015.

[6] Z. Xueguang, Z. Wenjie, C. Jiaming, and X. Dianguo, "Deadbeat control strategy of circulating currents in parallel connection

system of threephase PWM converter," *IEEE Trans. Energy Convers.*, vol. 29, no. 2, pp. 406–417, Jun. 2014.